

Airborne Telemetry

MSC1000-003 Accelerometer Conditioning Module (2 Channel)

Airborne Data Acquisition Products

FEATURES

- Each channel is independently programmable via DASM software
- Balance type is selectable as: amplifier offset or manual balance.
- 11 gains (1 to 1024)
- 16 programmable cutoff frequencies (8 Hz to 3125 Hz)
- Programmable input offset in 2.44 mV steps from -10 to +10V.
- Programmable excitation in 4.88 mA steps from 1 to 20 mA DC.
- ZCAL, NCAL, and VCAL.
- Sample and hold per channel.
- Overvoltage protected to $\pm 32\text{VDC}$
- Nominal channel accuracy of 0.5%



communications
Telemetry & RF Products

Excellence You Can Measure

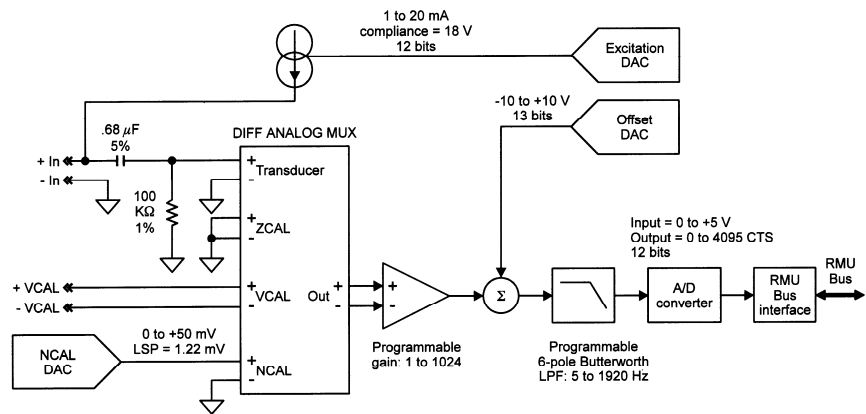

DESCRIPTION

The MSC1000-003 is a fully programmable signal conditioning module designed to interface to Piezo Accelerometers and Dynamic Strain Gages which require constant current rather than constant voltage.

FEATURES

Excitation (Per channel)

- Programmable in steps of 4.88 mA from 1 to 20 mA DC
- Accuracy: 0.5% of selected value
- Load regulation: $\pm 0.5\%$ of selected value from no load to full load (5V)
- Stability: $\pm 0.25\%$ of selected value over temperature
- Compliance voltage: 18V minimum

Input Characteristics (Per Channel)

- Input impedance: 100 Kohms at 500 Hz.
- Input configuration is a single-ended 1 pole high pass filter with 3db frequency of 2.3 Hz.
- Overvoltage protection to $\pm 32V$

Gains (Per Channel)

- Program selectable gains of 1, 2, 4, 8, 16, 32, 64, 128, 256, 512, and 1024.
- Gain accuracy: $\pm 0.5\%$ of selected value
- Gain temperature stability: $\pm 0.25\%$ of selected value
- Linearity: $\pm 0.1\%$ BSL

Channel Offset

- Programmable circuits for adjusting referenced to output (RTO) offset.
- Program selectable in 2.44 mV steps from -10VDC to +10VDC referenced to output
- Any signal between -7.5 and +12.5 Volts (referenced to output) can be offset to half scale output.
- Channel offset stability $\pm 0.2\%$ FS over temperature at a gain of 32

Pre-Sample Filter (Per Channel)

- Program selectable pass band frequencies of 5, 10, 15, 20, 30, 40, 60, 80, 120, 160, 240, 320, 480, 640, 960, and 1920 Hz.
- Within the passband, the amplitude response is flat to within 1% PP
- Attenuation at four times the passband frequency is 40db minimum
- 6 pole Butterworth response
- Inter-channel phase correlation within passband is ± 1.5 maximum

Cal Types

- NCAL: NCAL DAC connected to channel input 0 to 50 mV, 12.2 mV increments. Accuracy is $\pm 0.5\%$ of full scale at output to input. Temperature stability is ± 1 mV, referenced to input.
- VCAL: Channel inputs are connected to system VCAL.
- ZCAL: Channel inputs are connected to signal ground.

Balance (Per Channel)

- Algorithm is program selectable from amplifier offset, or manual balance.
- Balance Algorithm accuracy: $\pm 0.5\%$ full scale

Sample and Hold (Per Channel)

- Program selectable on minor frame, on major frame, or on word.

Output

- A 5 volt full scale analog at a gain of one (1), converted to a 12 bit digital word (1.22 mV/bit)

www.L-3Com.com/te



L-3 Communications Telemetry-East
1515 Grundy's Lane
Bristol, PA 19007
Tel: 267-545-7000
Fax: 267-545-0100



L-3 Communications Telemetry-West
9020 Balboa Avenue
San Diego, CA 92123-3507
Tel: 858-694-7500, 800-351-8483
Fax: 858-279-0693