

Airborne Telemetry

MSC1000-001

Strain Gauge Conditioner (2 Channel)

Airborne Data Acquisition Products

FEATURES

- Each channel is independently programmable via DASM software
- Balance type is selectable as: amplifier offset, transducer offset, transducer balance, or manual balance.
- 11 gains (1 to 1024)
- 6 pole pre-sample filter with selectable passband (5 to 1920 Hz)
- Offset range from -10V to +10V
- Excitation range from +1V to +10V with current limiting of 40 mA.
- ZCAL, NCAL, RCAL, and VCAL.
- Sample and hold per channel.
- Overvoltage protected to ± 32 VDC
- Nominal channel accuracy of 0.5%
- Bridge completion is available on the module. Consult the factory for details.

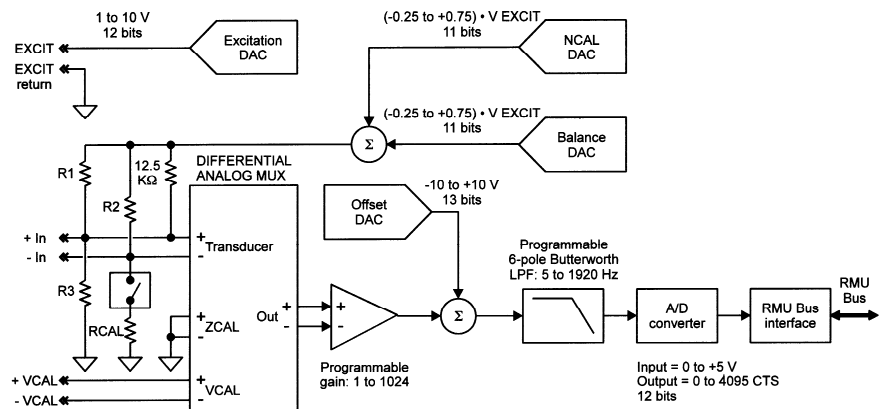

DESCRIPTION

The MSC1000-001 provides everything needed for precision strain gage measurements except for the sensor. This module is a fully programmable unit with the salient features. This module is a fully programmable unit with the above features.



communications
Telemetry & RF Products

Excellence You Can Measure

ELECTRICAL SPECIFICATIONS

Excitation (Per channel)

- Programmable in steps of 2.44 mV from +1VDC to +10VDC
- Accuracy: 0.5%
- Load regulation: $\pm 0.5\%$ from no load to full load (30 mA)
- Current limited to 40 mA

Differential Input Characteristics (Per Channel)

- Full scale range equals 5VPP differential
- Input impedance: 1 Megohm minimum
- ACCMR at a gain of 1 of 50 db minimum at 400 Hz with a 1 Kohm unbalance
- Overvoltage protection to $\pm 32V$

Gains (Per Channel)

- Program selectable gains of 1, 2, 4, 8, 16, 32, 64, 128, 256, 512, and 1024
- Gain accuracy: $\pm 0.5\%$ of selected value
- Gain temperature stability: $\pm 0.5\%$ of selected value, including effects of excitation drift
- Linearity: $\pm 0.1\%$ BSL

Channel Offset

- Program selectable in 2.44 mV steps from -10VDC to +10VDC referenced to output
- Channel offset stability $\pm 0.5\%$ FS over temperature at a gain of 32
- Offset capability: Any signal between -7.5V and +12.5V (referenced to output) can be offset to half scale output

Pre-Sample Filter (Per Channel)

- Program selectable pass band frequencies of 5, 10, 15, 20, 30, 40, 60, 80, 120, 160, 240, 320, 480, 640, 960, and 1920 Hz.
- Within the passband, inter-channel correlation is $\pm 1.5\%$ maximum
- Within the passband, the amplitude response is flat to within 1% PP
- Attenuation at four times the passband frequency is 40 db minimum
- 6 pole Butterworth response

Cal Types

- RCAL: Under software control, the bridge leg from (-) input to (-) excitation is shunted by an internal 300 Kohm resistor. RCAL Delta accuracy at channel output is $\pm 0.5\%$ full scale.
- NCAL: Delta accuracy at channel output is $\pm 0.5\%$ full scale. Range: ± 0.5 excitation voltage (via 12.5 Kohm) = ± 6.905 mV/V at channel input for a 350 ohm bridge. Temperature stability at channel output is $\pm 0.25\%$ full scale.
- VCAL: Channel inputs are connected to system VCAL.
- ZCAL: Channel inputs are connected to signal ground.

Balance (Per Channel)

- Algorithm is program selectable from transducer balance, transducer offset, amplifier offset, or manual balance.
- Transducer balance range: ± 0.5 excitation voltage (via 12.5 Kohm)
- Balance Algorithm accuracy: $\pm 0.5\%$ full scale

Sample and Hold (Per Channel)

- Program selectable on minor frame, on major frame, or on word.

Output

- A 5 volt full scale analog at a gain of one (1), converted to a 12 bit digital word (1.22 mV/bit)

www.L-3Com.com/te



L-3 Communications Telemetry-East
1515 Grundy's Lane
Bristol, PA 19007
Tel: 267-545-7000
Fax: 267-545-0100



L-3 Communications Telemetry-West
9020 Balboa Avenue
San Diego, CA 92123-3507
Tel: 858-694-7500, 800-351-8483
Fax: 858-279-0693