

MIL-SPEC NVIS Compatible Lighting Indicator

ML 1662

FEATURES

- Designed to meet MIL-L-85762A and MIL-STD-3009 Lighting, Aircraft, Interior Night Vision Imaging System (NVIS) compatible
- Environmentally Sealed
- Optional EMI Protection Screen
- Colors: Yellow, Green & Red
- Front Panel Mount Seal

The ML 1662 status indicator was developed to meet the requirements of MIL-L-85762A MIL-STD-3009. This solid state lamp with infrared blocking lens is compatible with NVIS environments. It is a panel mount device with solderable leads and includes hardware.



ML 1662

ENVIRONMENTAL SPECIFICATIONS

Vibration: .06" D.A. or 20G Peak, whichever is less, 10 Hz to 2 kHz, MIL STD 202, Method 204, Test Condition D.

Shock: 100 G's MIL STD 202, Method 213, Test Condition I.

Moisture Resistance (Humidity): MIL STD 202, Method 106.

Altitude: 100,000 ft., MIL STD 202, Method 105, Test Condition D.

Reliability: Operational 6×10^6 hours min. MTBF @ 25°C

Salt Spray: MIL STD 202, Method 101, Test Condition B.

MECHANICAL SPECIFICATIONS

Case: aluminum, black anodized bezel with clear chromate body.

Mounting: Front panel by 5/16-32" nut and lockwasher.

Seal: Environmentally sealed with front panel PTFE ring seal.

ELECTRO-OPTICAL CHARACTERISTIC SPECIFICATIONS Absolute Maximum Ratings

Color	Red	Yellow	Green
Forward Voltage (VDC)	2.4	2.0	2.1
Peak Forward Current (mA)	50	60	90
DC Forward Current (mA)	25	20	30
Reverse Voltage (VDC) @ $I_R = 100 \mu A$	4	5	5
Power Dissipation (mW)	70 ¹	85 ²	135 ³
Luminous Intensity (mcd)	3	5	10
NVIS Radiance per MIL-L-85762A & MIL-STD-3009	$NR_B 1.4 \times 10^{-7}$ @ 15 fL	$NR_A 1.5 \times 10^{-7}$ $NR_B 1.4 \times 10^{-7}$ @ 15 fL	$NR_A 1.7 \times 10^{-10}$ $NR_B 1.7 \times 10^{-10}$ @ 0.1 fL
Dominant Wave Length (nm)	620	585	569
Viewing Angle ($2 \theta^{1/2}$)	50°	50°	50°
Operating Temperature (°C)	-20 to +70	-55 to +100	-20 to +100
Storage Temperature (°C)	-20 to +100	-55 to +100	-55 to +100

¹Derate at 1.8 mW/°C above +25°C Ambient

²Derate at 1.6 mW/°C above +50°C Ambient

³Derate at 1.6 mW/°C above 25°C Ambient

ORDERING INFORMATION

When ordering, show model number first, then LED color, EMI screen, body finish, and the terminal style desired. If this is a special part, customer's modification number will be added at the end of the ordering number.

Example: Basic model with in with red LED., with a screen, a clear chromate body finish, and a tin lead terminal finish would be model ML 1662 -G - 1 - 2 - 1.

ML1662 - G - 1 - 2 - 1 - S ()					
Basic Model Number	Color LED	EMI Screen	Body Finish Color	Terminal Style Color	Factory Modification Number if Special
ML 1662	(R) Red (Y) Yellow (G) Green	(0) None (1) Screen	(2) Clear Chromate	(1) Tin Lead	S+ ID No.



MIL-SPEC NVIS Compatible Lighting Indicator ML 1662



ML 1662

Model ML 1662

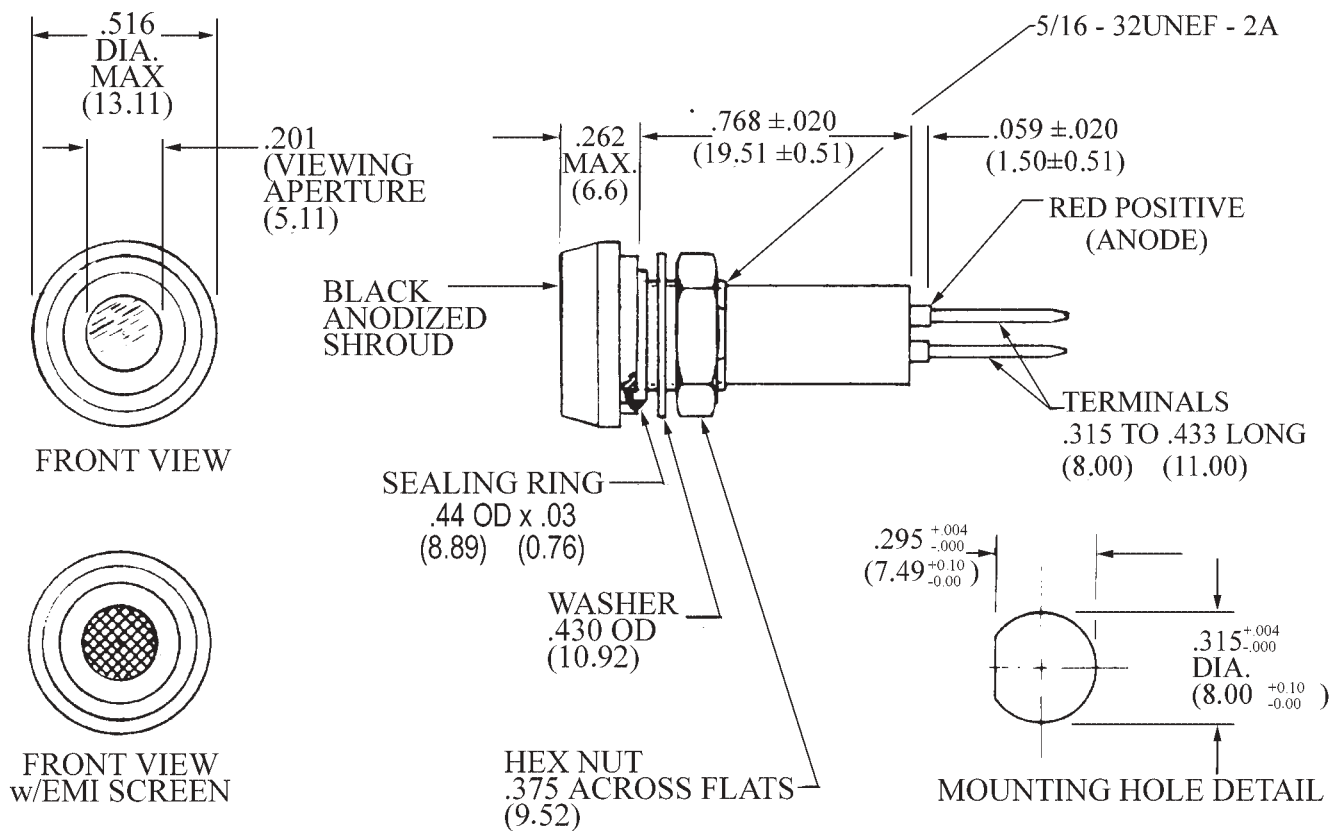

LED INDICATORS

NOTE:

Dimensions in () are mm. Tolerances: Decimals: ± .010 (0.25) Fractions: ± 1/64 Mounting Torque: 5-7 in. lbs.

L-3 Communications / ElectroDynamics • 1200 Hicks Road • Rolling Meadows, IL 60008 • Tel: 847.660-1750 • Fax: 847.660-1751 • email: edi.info@L-3com.com • www.L-3com.com/edi

Cleared by DoD/FOISR for public release under reference number 00-S-1235 on April 17, 2000.