



L5652 Traveling Wave Tube

Features

- **Dual Mode Operation**
- **X-Band PPM**
- **High Efficiency/High Duty**
- **Grid Pulsed**
- **Liquid Cooled**



Typical Performance (at 10GHz)

	High Mode	Low Mode
Pulsed Power Output	40 KW	4.5 KW
Average Power Output	1400 W	1100 W
Power Input	+9 dBm	+33 dBm
Phase Pushing		
Cathode Voltage.....	36°/%	34°/%
Grid Voltage	5°/%	4°/%
Duty	3.5%	25%

Mechanical

Mounting.....	Position Any
Weight	24 lbs
Dimensions.....	See Outline Dwg

Typical Operating Conditions

	High Mode	Low Mode
Cathode Voltage	-35 KV	-35 KV
Peak Cathode Current	6.0 A	1.4 A
Collector Voltage No.1		20.65 KV
Collector Voltage No.2		13.3 KV
Collector Voltage No.3		9.1 KV
Peak Body Current.....	1000 mA	50 mA
Grid Bias	-400 V	-400 V
Peak Grid Drive-Inner	Note A	Note A
Peak Grid Drive-Outer	Note A	-450 V
Peak Grid Current	2 ma	2 ma
Heater Voltage		-11.0 VDC
Heater Current		3.6 A
Cooling-Coolanol 20/25	2.0GPM	2.0GPM
FC75/77	12PSI	12PSI

All voltages are with respect to cathode
Note A: +350 ± 100 V

The L5652 X-Band Dual Mode Coupled Cavity Traveling Wave Tube provides power levels up to 40 kilowatts peak and 1400 Watts average in the high mode, and 4.5 kilowatts peak and 1100 Watts average in the low mode. It has a dual mode gun that employs two concentric-ring control grids in addition to a shadow grid. The depressed collectors provide an overall efficiency of 36% at the maximum power output in each mode.

The L5652 is liquid cooled and has PPM focusing utilizing samarium cobalt magnets. DS56520706

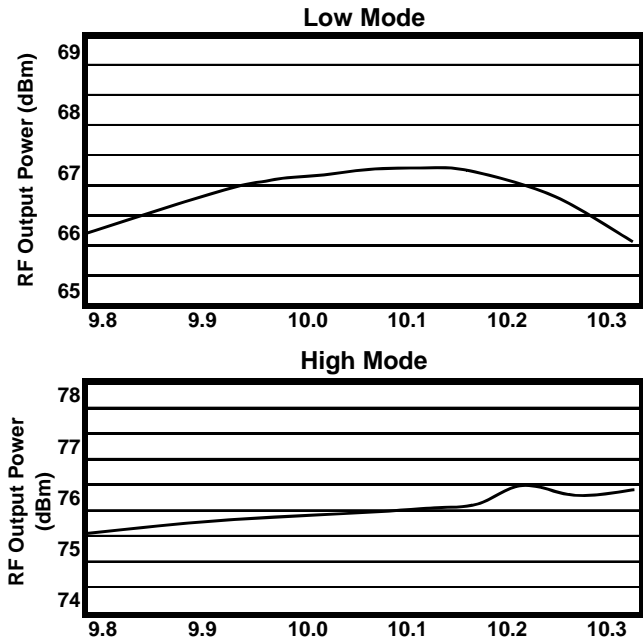

Cleared by DoD/DFOISR for public release under 02-S-2501 dated 9/4/02

L5652 Outline Drawing

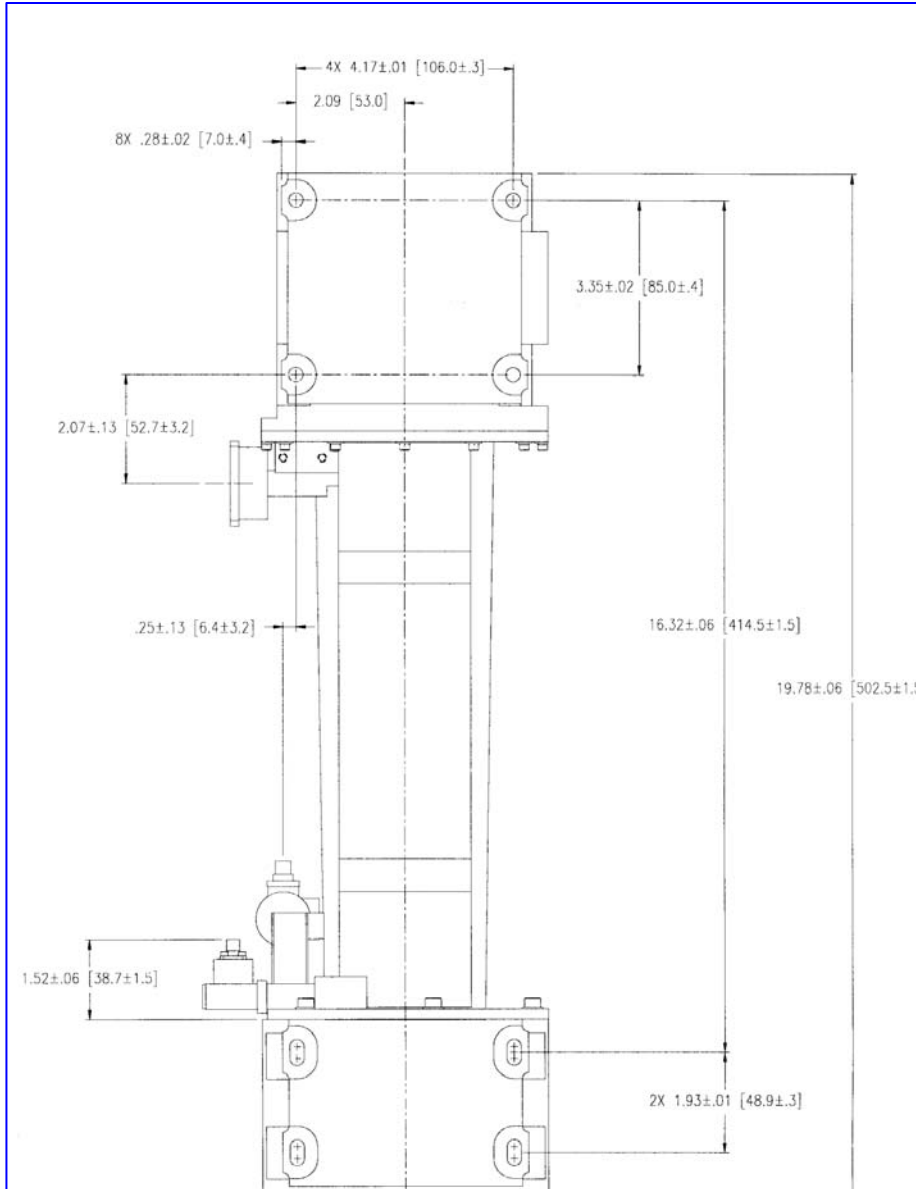

communications
Electron Devices

Electron Devices
960 Industrial Road, San Carlos, CA 94070
(650) 591-8411 Fax: (650) 508-1956
Web Site: www.L-3com.com/edd
E-mail: scl.marketing@L-3com.com